

CROSS SECTION

SCALE: 1:10

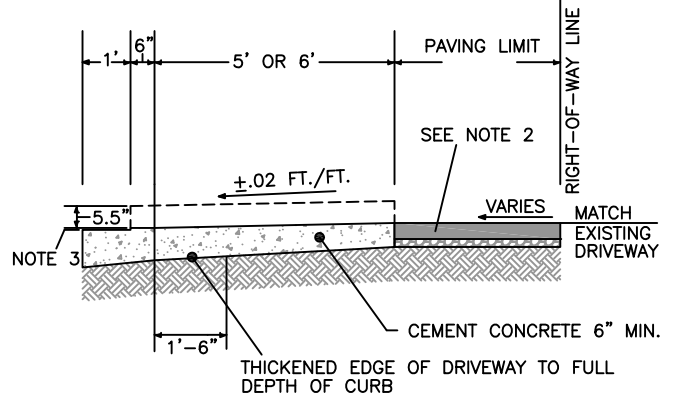

SECTION A-A

SCALE: 1:4

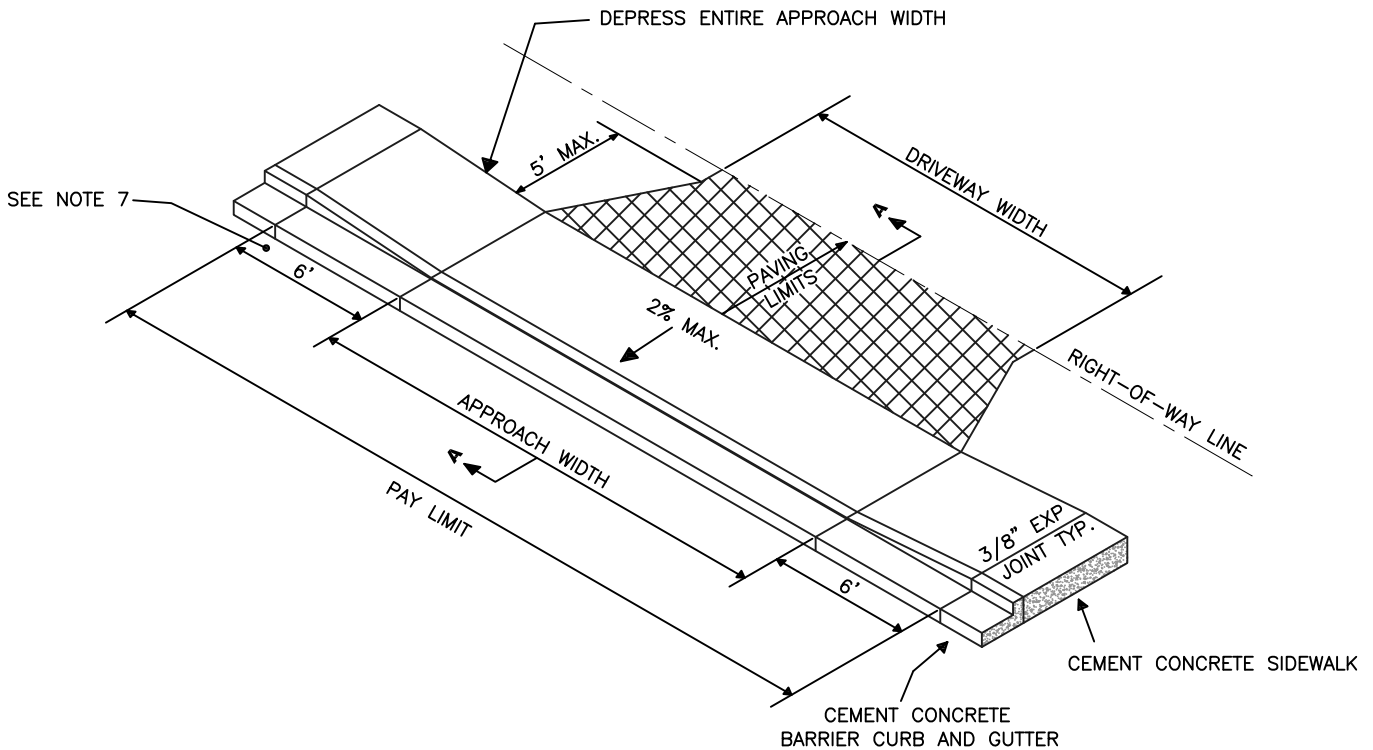

NOTES:

- 1) DRIVEWAY WIDTH = 15' MINIMUM TO 30' MAXIMUM. TOTAL APPROACH WIDTH SHALL NOT EXCEED 50% OF THE PROPERTY FRONTAGE.
- 2) DRIVEWAY PAVING = 6" MINIMUM CEMENT CONCRETE OR 2" MINIMUM COMPACTED DEPTH ASPHALT CONCRETE PAVEMENT CLASS B, OVER 2" MINIMUM DEPTH CRUSHED SURFACING TOP COURSE.
- 3) LIP HEIGHT 1/2", 1" FOR REVERSE GRADE APPROACHES.
- 4) STORM DRAINAGE FROM DRIVEWAY SHALL NOT BE PERMITTED TO DRAIN ONTO ROADWAY SURFACE, UNLESS ACCOUNTED FOR IN DESIGN.
- 5) DRIVEWAY SHALL NORMALLY BE AT 90 DEGREES TO ROAD CENTERLINE, BUT CAN VARY FROM 75 DEGREES TO 90 DEGREES.
- 6) RECOMMENDED MAXIMUM GRADES +/- 15% BEYOND GRADE BREAK POINT. VERTICAL CURVES NOT TO EXCEED 3.25" CREST OR A 1" SAG IN A 10' CHORD.
- 7) ADJUST THE RAMP LENGTHS TO MEET ADA REQUIREMENTS, 15' MAXIMUM LENGTH.
- 8) ENTERING SIGHT DISTANCE SHALL MEET AASHTO STANDARDS.

SCALE: 1:8



CITY OF PUYALLUP

DEVELOPMENT ENGINEERING and PUBLIC WORKS DEPARTMENTS

RESIDENTIAL DRIVEWAY ALTERNATE 1

DRAWN BY JIM ERWIN-SVOBODA	CHECKED BY LINDA LIAN	APPROVED BY COLLEEN HARRIS	REVISED BY LINDA LIAN	CITY STANDARD
FILE NAME F:\DWG\COMMON\STDS\CITY\2009\01_STR\01.02\01.02.13	DATE APPROVED 07/01/2009	DATE REVISED 03/21/11	SCALE VARIES	01.02.13